

DMX EP-TOUCH-3 CONTROLLER



Product Introduction:

The third generation EP-TOUCH is the flagship controller from Epic Global Control System. The EP-TOUCH-3 can be adapted to any environment. Control dynamic lighting inside a house, bar, office block, shopping center, hotel or even a landmark. With 1024 DMX output channels and the ability to store 500 scenes across 10 zones, the DE3 is one of the best value controllers on the market today.

Performance Parameter

Package	Interface, sdcart, datasheet, cdrom, usb cable	
Software	ESA + ESA PRO on PC/Windows, ESA2 on PC + MAC	
Mobile Application	DMX Lightpad 3 + ARCOLIS on iPhone/iPad/Android	
Available colors	Black frame, various front panel design	
Standards	EC, EMC, ROHS, ETL, UL (some are in process)	
Temperature	-10°C to 45°C	
Dimensions	146x106x11 mm	Complete package 177x146x48 mm
Weight	247 g 8.71 oz	Complete package 492 g 17.4 oz

Specification

CONNECTION SPECIFICATIONS		Built-in features	Screw-terminal rear connector (5 pins)	Extension socket rear connectors (2x10 pins)	Power+DMX socket (RJ45)	Ethernet socket (RJ45)	Front access connections
Power Supply	6 V DC 0.6A, optional*				•U		SB
DMX Output #1F	first universe, 512 channels DMX512 output		••		•		
DMX Output #2S	second universe, 512 channels DMX512 output			•	•		
USB	SB communication for PC/Mac software						•
Ethernet	Advanced networking features					•	
Ports 1,2,...,8	8 Contact closure inputs, connect to ground for operating			•			
User interface	10 buttons, 1 wheel, 1 color display, 5 leds (Touch-sensitive keypad)	•					power/data leds
SD card	Micro sd card for stand alone memory use (supplied)						•
RESET	Push button for feet operation						•
RS232	RS232 serial communication for external synchronisation			•			
Output relay	Automatic standby 5V signal •						
ClockR	real-time clock and calendar*						

OPTIONS / ACCESSORIES	
RJ2BLOCK	RJ45 to connector block converter for POWER+DMX
POWER4MD	dedicated power adapter 110-220V to 6VDC
VERSIONS	WHITE OR BLACK front panel, choices of wheel design



Dimensions

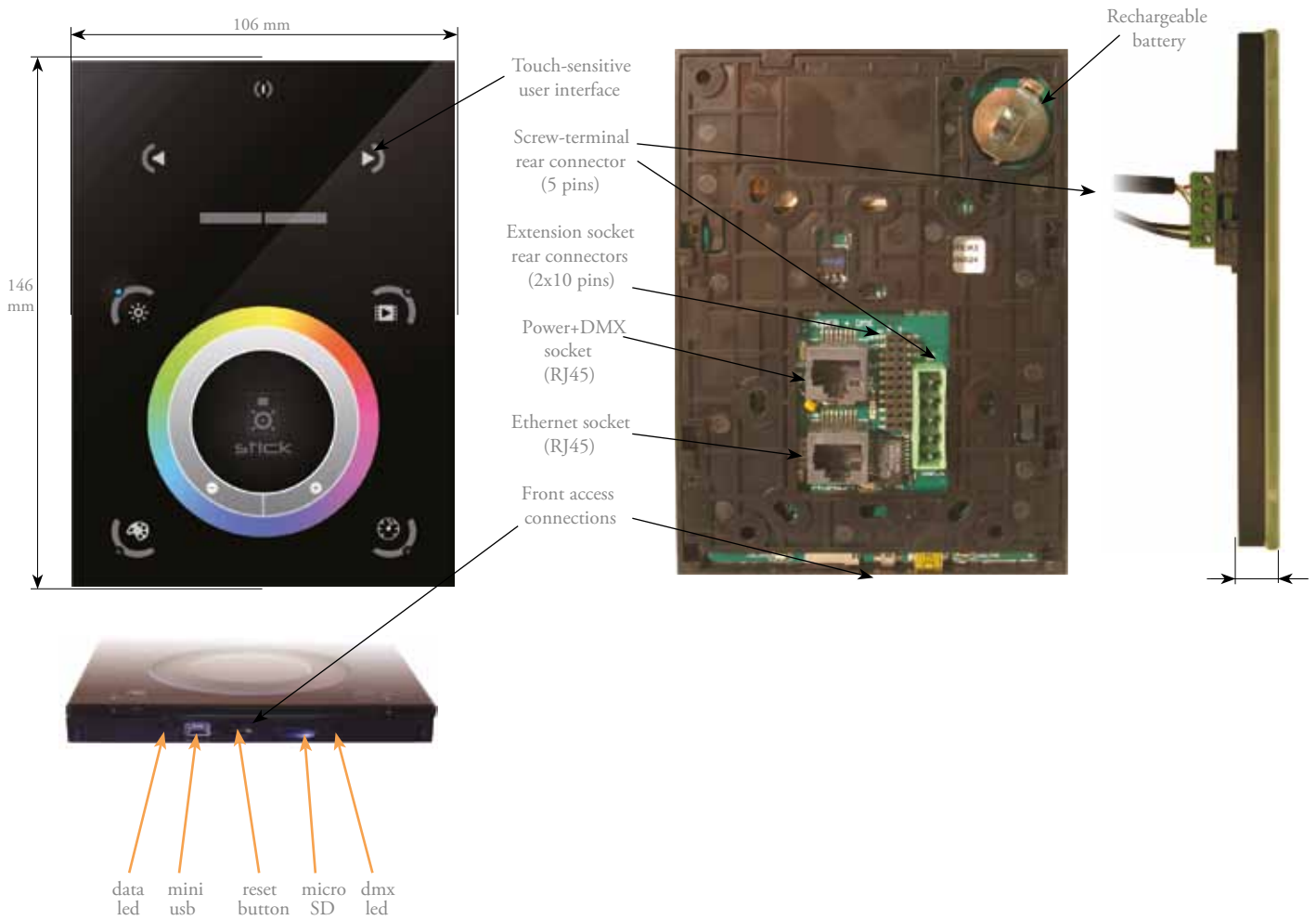

DMX EP-TOUCH-3 CONTROLLER

Installation



1. Mount an electrical box inside the wall

The EP-TOUCH-3 controller can be installed in any standard electrical backbox. If you use a double size box, you can insert the power supply inside.

2. Connect the wires

POWER: Connect a 5.5V or 6V DC 0.6A. Be sure to not invert the + and the ground.

DMX: Connect the DMX cable to the lighting receivers (Leds, Dimmers, Fixtures..) (for XLR: 1=ground 2=dmx- 3=dmx+)

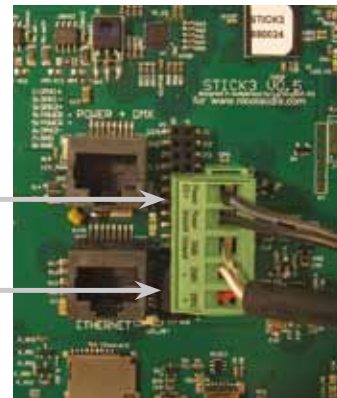

3. Mount the interface on the wall

First, mount the back side of the interface on the wall with 2 or more screws

Secondly, plug the connectors :

- Ethernet cable
- DMX and power (connector block or RJ45)



POWER+DMX
WITH THE
CONNECTOR BLOCK



POWER+DMX
WITH THE
RJ45 C ABLE

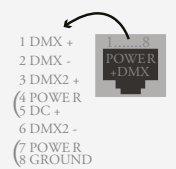

2x10 pins EXTENSION connector

DMX CHIPS can be replaced here

DMX universe #1

DMX universe #2

Ref: SP485ECN-L
MAX485 CSA



VIN	20	19	PORT1
GND	18	17	PORT2
IR_RX	16	15	PORT3
3.3V	14	13	PORT4
Relay	12	11	PORT5
DMX2+	10	9	PORT6
DMX2-	8	7	PORT7
DMX1+	6	5	PORT8
DMX1-	4	3	RS232 RX
GND_DMXX	2	1	RS232 TX

Compatible connectors:
 WURTH ELEKTRONIK ref: 61301021121
 MOLEX ref: 10-89-7202
 TE Connectivity ref: 1-87227-0
 FCI ref: 77313-101-20LF
 HARWIN ref: M20-9981046
 SAMTEC ref: TSW-110-xx-T-D
 FARNELL ref: 1841232
 RS ref: 763-6754 673-7534 251-8165
 MOUSER ref: 538-10-89-7202
 DIGIKEY ref: WM26820-ND

BLACKOUT relay
 (energy saving)
 using the 2 pins : BK
 and G (GND)

Example of relay : FINDER
 Ref. 22.23.9.012.4000
<http://www.findernet.com/fr/products/profiles.php?serie=22&lang=en>

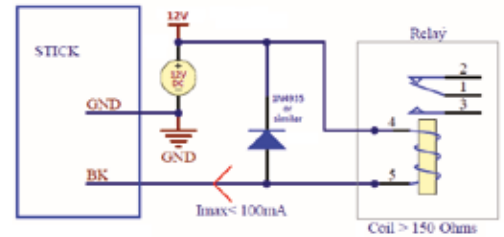

RS232 triggering

Make a cable using the 3 pins : TX, RX and G (GND)

Set the RS232 parameters to : 9600bds 8 bits, no Parity, 2 Stop bits

- To play a scene, send 3 bytes : 1 x 255 (x = scene number)
- To stop a scene, send 3 bytes : 2 x 255 (x = scene number)
- To pause a scene, send 3 bytes : 3 x 255 (x = scene number)
- To release a pause, send 3 bytes : 4 x 255 (x = scene number)
- To reset a scene, send 3 bytes : 5 x 255 (x = scene number)

Note: the scene number (x) can be from 1 to 40. For instance, 11 means Page B Scene #3

PORTS triggering

It is possible to start scenes using the input ports (contact closure). To activate a port, a brief contact must be established between the ports (1...8) and the ground (GND). This is a contact closure so there is no need to hold the connection, it acts like a basic switch.

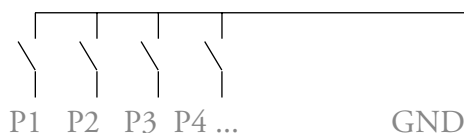

DMX EP-TOUCH-3 CONTROLLER

Internal Menu - hardware Configuration



Press and hold the ON/OFF button for 3 seconds to get into the settings menu. Here are the available parameters:

- Mode (M) : allows to enable/disable speed/dimmer/...buttons
- Arrows (A) : allows to change the function of < and > arrows
- Palet (P) : allows to enable/disable the palet functions (speed/dimmer/color)
- Scene (S) : allows to change various settings (fade time, pause/stop...)
- First Start (F) : allows to setup what to do at startup (play a scene, blackout, etc...)
- Trigger (T) : allows to enable/disable triggers (RS232, IR, ports...)
- Ethernet (E) : allows to setup Ethernet parameters (IP address...)
- Date/Time (T) : allows to change date and time of the device
- Graphics (G) : allows to change the display settings (sleep mode, brightness...)
- DMX output (X) : allows to change the DMX signal parameters (speed...)
- Diagnostic: shows date/time, firmware version . . .
- Reset : allows to reset the unit to factory settings

The < and > arrows allows you to move the cursor in the menu or change a value, the ZONE+ buttons allows you to edit/validate a value or enter a submenu, the ZONE- button allows you to return to the previous menu/submenu (read the hardware manual for a complete description).

SOFTWARE

ARCOLIS software (Touch Lighting Editor app for iPhone/iPad, Android)
 DMX Lightpad 3 (Remote application for iPhone/iPad, Android, Windows)
 =>download your application from Google Play, Apple App Store or Windows Mobile website

ESA, ESAPRO software (Windows)
 ESA2 software (Windows, Mac)
 ESA, ESAPRO manuals

Driver, Firmware, Tools

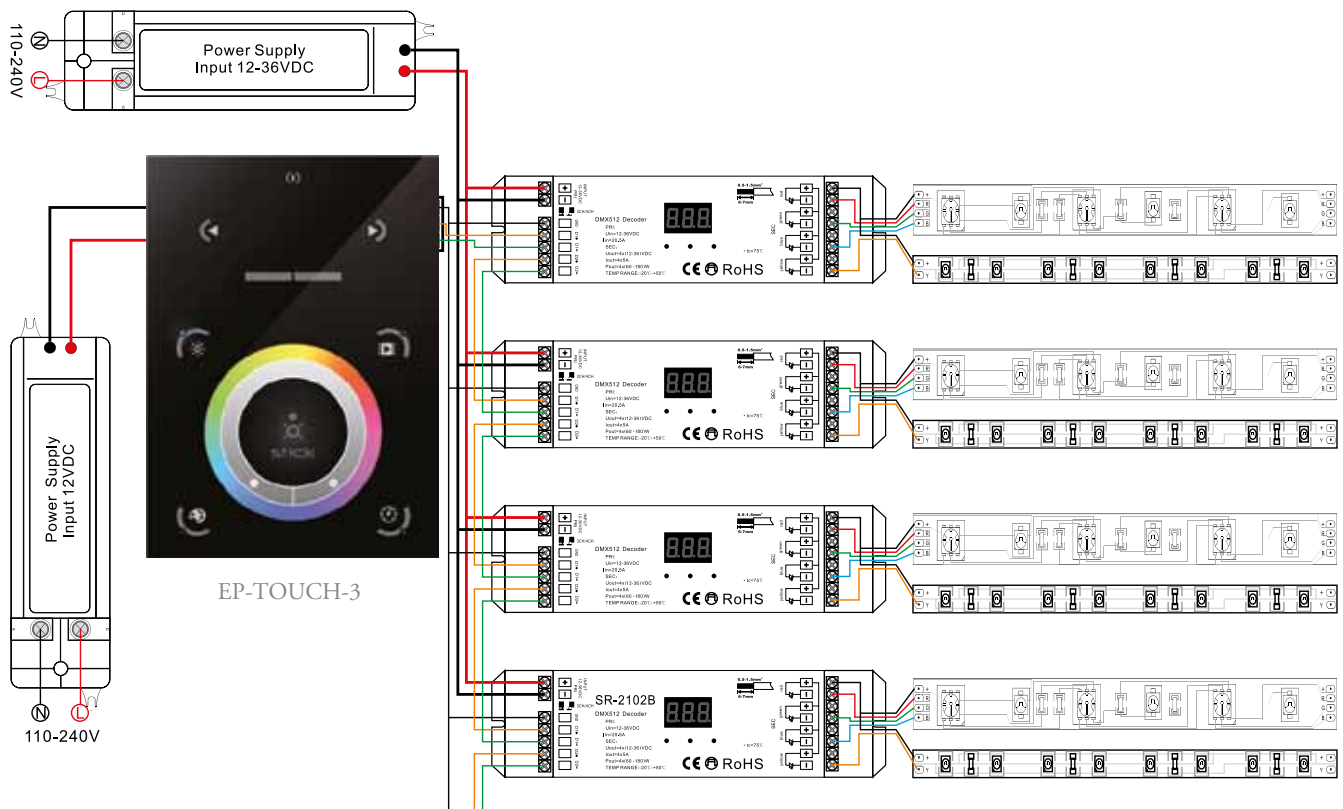

NETWORK SYNCHRONIZATION

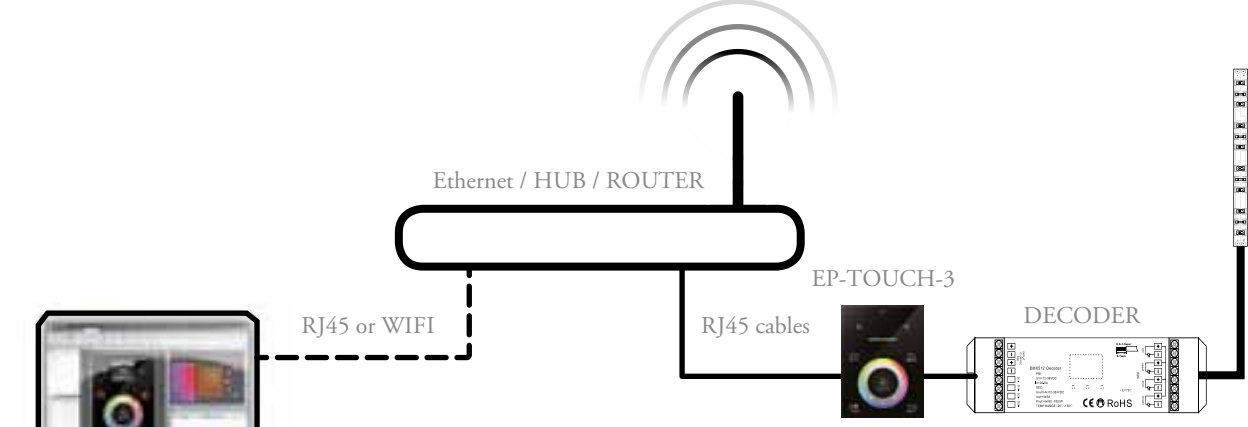

To access Ethernet network features, you need a EP-TOUCH-1 or a EP-TOUCH-3 .

